

SAILING INSTRUCTIONS

HAMPTON ONE DESIGN NATIONAL CHAMPIONSHIP

Hampton One Design Class Racing Association Hampton Yacht Club – August 11, 12, & 13, 2023

1. RULES

- 1.1 The regatta will be governed by the Racing Rules of Sailing, 2021-2024, US Sailing Prescriptions and the Hampton One Design Class Rules.
- 1.2 RRS Appendix V1 PENALTY AT THE TIME OF AN INCIDENT will apply. This changes RRS44.1
- 1.3 Rule 49.1 is changed to allow hiking pads.

2. NOTICES TO COMPETITORS

- 2.1 Notices to competitors will be posted on the Official Notice Board online at <https://yachtscoring.com/emenu.cfm?eid=15888>
- 2.2 Unofficial courtesy copies of such notices may also be posted at the Hampton Yacht Club clubhouse.

3. CHANGES TO THE SAILING INSTRUCTIONS

- 3.1 Any change to the Sailing Instructions will be posted before 0830 on the day it will take effect, except that any change in the schedule of races will be posted by 2000 on the day before it will take effect.
- 3.2 Oral changes to the sailing instructions are allowed to be made while on the water as per RRS 90.2(c). If they are to be made flag L will be flown. Boats should sail by the signal boat to receive the instructions and acknowledge receipt.

4. SIGNALS MADE ASHORE

- 4.1 Signals made ashore will be displayed from the yard arm of the Hampton Yacht Club flagpole.
- 4.2 When flag “AP” is displayed ashore “1 minute” is replaced with “not less than 60 minutes” in the race signal AP.

5. SCHEDULE OF RACES

- 5.1 Registration and entry fee payment is online at: <https://yachtscoring.com/emenu.cfm?eid=15888>
- 5.2 On-site check-in will begin at 1000 and close at 1150 on Friday August 11th. All registrants must check in that Friday.
- 5.3 A Competitors’ Meeting will be held Friday, August 11th at noon on the patio by the clubhouse.
- 5.4 The racing schedule will be:

<u>Day & Date</u>	<u>Race</u>	<u>Time</u>
Friday, Aug 11	Harbor Start	1230
Friday, Aug 11	1	1400 - Warning
Friday, Aug 11	2	Immediately after Race 1
Saturday, Aug 12	Harbor Start	0900
Saturday, Aug 12	3	1030 - Warning
Saturday, Aug 12	4	Immediately after Race 3
Saturday, Aug 12	5	Immediately after Race 4
Sunday, Aug 13	Harbor Start	0900
Sunday, Aug 13	6	1030 - Warning
Sunday, Aug 13	Make-Up	Immediately following (if required)

- 5.5 No starting sequence will begin after 1500, Sunday, August 13th.
- 5.6 Flag A displayed with no sound, while boats are finishing means “No more racing today”

6. **CLASS FLAG**
The class flag will be the HOD logo.
7. **RACING AREA**
The racing area will be on Hampton Flats.
8. **COURSES**
 - 8.1 The courses to be used are shown in Appendix A.
 - 8.2 The approximate bearing and distance from the Signal Boat to Mark 1 will be displayed on the Signal Boat before the warning signal for each race along with the course letter to be sailed.
 - 8.3 All marks shall be left to port.
9. **MARKS**
 - 9.1 Marks 1, 2, and G will be 3' orange inflatables.
 - 9.2 The starting pin will be a 2' red inflatable.
 - 9.3 The first change mark as provided in SI 13, will be a 3' yellow inflatable.
 - 9.4 Downwind finish mark will be 2' orange polyform buoy.
 - 9.5 Upwind finish mark will be the windward mark.
10. **CHECK-IN/CHECK OUT**
 - 10.1 Prior to the warning signal for the first race of each day, each boat shall sail past the stern of the RC Signal Boat and hail her sail number until acknowledged by the Race Committee. Only the Race Committee can protest an alleged breach of this instruction. This changes RRS 60.1.
 - 10.2 A boat leaving the course area is requested to notify the Race Committee before leaving or, if that is not possible, to notify the PRO immediately upon arriving ashore by calling or texting 757-581-0781.
11. **THE START**
 - 11.1 Races will be started using RRS 26.
 - 11.2 The starting line will be between a staff displaying an orange flag on the RC Signal Boat at the starboard end and the course side of the port-end starting mark.
 - 11.3 An orange limit buoy may be tethered to the stern of the RC Signal Boat. Any boat hitting this buoy will be considered to have broken RRS 31.
 - 11.4 A boat that does not start within 10 minutes of her starting signal will be scored DNS without a hearing. This changes RRS A5.1 and A5.2.
12. **RECALLS**
The Race Committee will attempt to hail the sail number of OCS boats after the starting signal over VHF channel 72 and/or megaphone. Failure to hail any boats, the timeliness of the hail, or the order of boats in the hail shall not be grounds for granting redress. This changes RRS 62.1(a).
13. **CHANGING THE NEXT LEG OF THE COURSE**
To change the next leg of the course, the Race Committee will lay a new mark (or move the finish line) and remove the original mark as soon as practicable. When in a subsequent change a new mark is replaced, it will be replaced by an original mark.
14. **THE FINISH**
Unless the race is shortened, the finish line for an upwind finish will be between the staff displaying a blue flag on a Race Committee boat and the weather mark and for a downwind finish between the staff displaying a blue flag on the signal boat and orange ball on the opposite side from the starting line.

15. **PENALTY SYSTEM**

The first two sentences of rule 44.1 are changed to: “A boat may take a One-Turn Penalty when she may have broken one or more rules of Part 2 or rule 31 in an incident while racing. However, when she may have broken one or more rules of Part 2 while in the zone around a mark other than a starting mark, her penalty shall be a Two-Turns Penalty.” RRS Appendix V1 applies.

16. **TIME LIMITS**

16.1 The time limit for the first boat to sail the course and finish is 1 hour and 45 minutes.

16.2 Boats failing to finish within 45 minutes of the first boat to sail the course and finish will be scored two (2) points more than the number of boats who sailed the course and finished within the time limit but not worse than DNF. This changes RRS 35, A5.1, A5.2, A10 and Class Rule Article VIII, 5.

17. **PROTESTS**

17.1 A boat intending to protest another boat must notify the Race Committee Finish Boat immediately after finishing and be acknowledged by the Race Committee. This changes RRS 61.1(a).

17.2 The written protest must be delivered to the Race Committee within one hour of the Signal Boat docking. The protest time limit will be posted on the Official Notice Board.

17.3 A notice of protests filed and hearing times will be posted on the Official Notice Board within 15 minutes after the expiration of protest time. This posting constitutes the notice required for Race Committee or Protest Committee protests required by RRS 61.1(b).

17.4 Hearings will be held as soon as possible following racing. It is the responsibility of each competitor to check the Official Notice Board to see if he/she has been cited in a protest.

18. **SCORING**

18.1 The Low Point Scoring System of Appendix A will be used.

18.2 Three races must be completed to constitute a series. This changes Class Rule Article VIII, 1.

18.3 If fewer than six races are completed, a boat’s series score will be the total of her race scores. If six races are completed, a boat’s series score will be the total of her race scores excluding her worst score.

19. **EQUIPMENT & INSPECTION**

Class rules require each boat to carry a paddle, a 15-pound anchor or equivalent in manufacturer's rating, 50 feet of ¼” anchor line, and 2 wearable life jackets. In addition, each boat shall carry a VHF radio capable of transmitting and receiving on channel 72. In accordance with class rules, competitors must designate a maximum of two sets of measured sails to be used during the regatta. This equipment and sails must be verified by class measurers prior to the competitors meeting on Friday.

20. **REPLACEMENT OF CREW**

Substitution of competitors will not be allowed without prior written approval of the National Executive Committee.

21. **PRIZES**

Trophies shall be given to helmsman and crew for the first five places. Also, the **J.W. Hurst** perpetual trophy will be awarded to the highest placing novice. Novice is defined as a competitor that has not won a CBYRA sanctioned event. The Regatta Chairman will post a list of eligible competitors for the Hurst Trophy prior to the first race. The **William J. Daugherty Memorial Trophy** will be awarded to the best crew of the year. The **T. Lane Stokes Cup** will be awarded to the Hampton One Design sailor (skipper or crew) who: exhibits exemplary sportsmanship, actively participates in Hampton One Design regattas, and actively promotes the Hampton One Design Class. The **Charles H. McCoy, Jr. Hampton One Design High Point Trophy** will be awarded to the skipper with the most points as outlined in the Sea Chest document.

22. **DISCLAIMER OF LIABILITY**

Competitors participate in the regatta at their own risk. See Rule 4, Decision to Race. The organizing authority, PRO, or Race Committee will not accept any liability for material damage or personal injury, or death sustained in conjunction with or prior to, during, or after the regatta. Each helmsman and crew must sign the waiver at Friday check in. If under age 18 parent/guardian must sign.

Appendix A

Course T

Course W3

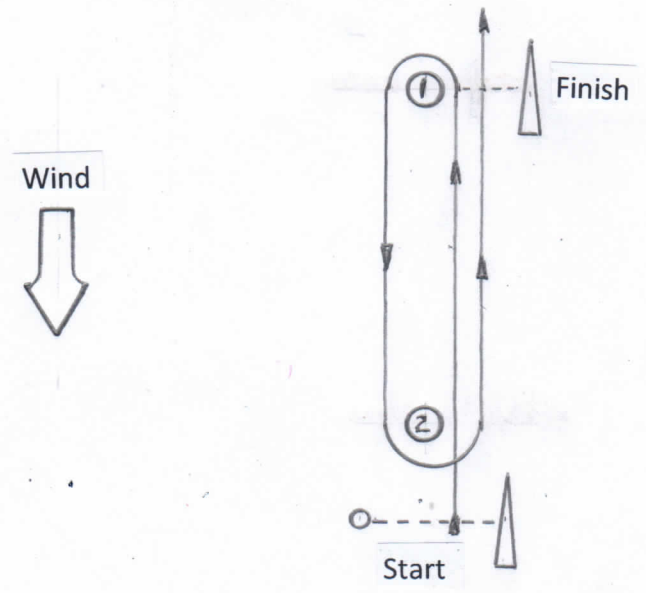
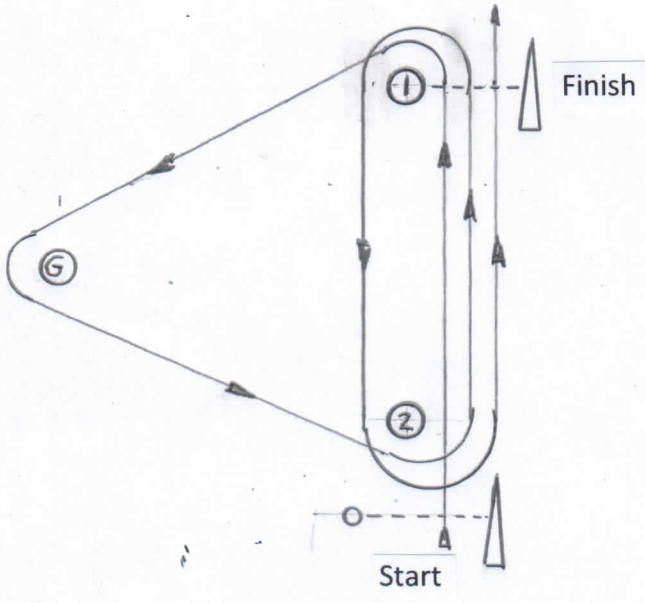

Course W5

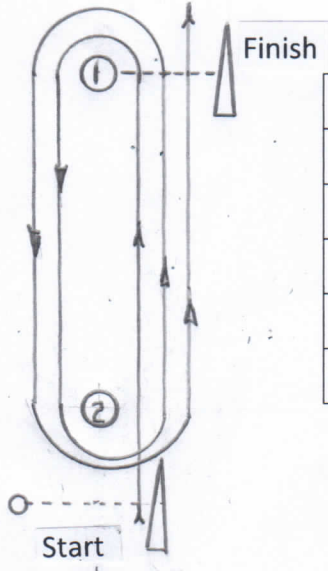

Course	Description
T	Start-1-G-2-1-2-Upwind Finish
W3	Start-1-2-Upwind Finish
W5	Start-1-2-1-2-Upwind Finish
L4	Start-1-2-1-Downwind Finish
L6	Start-1-2-1-2-1-Downwind Finish

Course L4

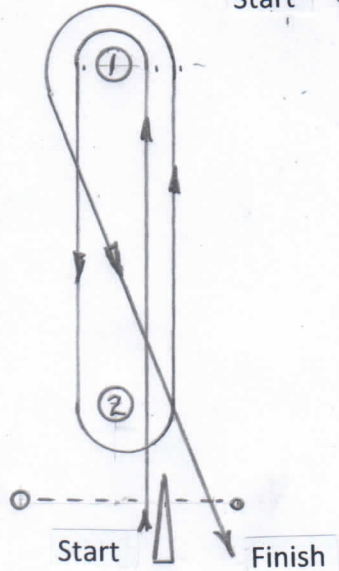

Course L6

