



# J/70 UK National Championship

## August 26<sup>th</sup> to August 28<sup>th</sup> 2023

**Weymouth and Portland National Sailing Academy,  
Portland, United Kingdom**

## SAILING INSTRUCTIONS

The Organising Authority (OA) is Weymouth and Portland National Sailing Academy (WPNSA) and the UK & Ireland J/70 Class Association.

Event Website: <https://yachtscoring.com/emenu.cfm?eID=15892>  
See SI 31 for full contact information

---

*The notation "[NP]" in a rule means that a boat may not protest another boat or request redress for a violation of that rule. This changes RRS 60.1.*

### 1. RULES

1.1 The event is governed by the rules as defined in The Racing Rules of Sailing.

### 2. CHANGES TO SAILING INSTRUCTIONS

Any change to the SIs will be posted before 09:00 on the day it will take effect, except that any change to the schedule of races will be posted by 20:00 on the day before it will take effect.

### 3. COMMUNICATION

- 3.1 Notices to competitors will be posted on the Official Notice Board which will be online at <https://yachtscoring.com/emenu.cfm?eID=15892>
- 3.2 The Race Committee (RC) may make courtesy broadcasts to competitors via the Telegram messaging system as outlined in **Addendum D**. It is strongly recommended that all competitors join this group.
- 3.3 The race office is located in Room 4 at WPNSA.
- 3.4 Any questions regarding the NoR or these SIs shall be submitted in writing to the Race Committee (RC). The questions and any answers will be posted as in SI 3.1.
- 3.5 A competitors' briefing will be held at 1000 on Saturday August 26<sup>th</sup> in Spinnakers.
- 3.6 The RC intends to monitor and communicate with competitors on VHF radio channel 60 'the VHF Channel'. Failure of the RC to broadcast, mistaken broadcasts, or failure of a competitor to receive this information will not be grounds for a request for redress. This changes RRS 60.1(b).
- 3.7 [NP] [DP] Boats shall use the radio to report retirement from racing and may use the radio to request or provide assistance in an emergency.
- 3.8 [DP] Except as provided in SI 3.7, from the first warning signal until the end of the last race of the day, except in an emergency, a boat shall not make voice or data transmissions and shall not receive voice or data communication that is not available to all boats.

### 4. CODE OF CONDUCT

- 4.1 [DP] Competitors and support persons shall comply with reasonable requests from race officials.

### 5. SIGNALS MADE ASHORE

- 5.1 Signals made ashore will be displayed on the flagpoles on the balcony outside the southeast corner of the Event Hall.
- 5.2 When flag AP is displayed ashore, "1 minute" is replaced with the time specified in the table below in Race Signals AP.
- 5.3 The table below shows the flag to be displayed (approximately 90 minutes before the published start time) to signify the intended sailing area and the minimum time from flag AP being removed until the first warning signal:

Sailing Area	Signal	Min time
Portland Harbour	Flag P	30 minutes
Weymouth Bay	Flag W	60 minutes

## 6. SCHEDULE AND FORMAT OF RACES

### 6.1 Schedule

Thursday	Aug 24th	09:00 – 16:00	Launching of boats
Friday	Aug 25th	09:00 – 16:00	Check-in and Launching of boats
Saturday	Aug 26th	08:00 – 09:30	Check-in and Launching of boats
		10:00	Competitors' Briefing
		11:55	First warning signal - subsequent race(s) to start ASAP
Sunday	Aug 27th	11:25	First warning signal - subsequent race(s) to start ASAP
		After Racing	Tideway Party
Monday	Aug 28th	11:25	First warning signal - subsequent race(s) to start ASAP
		After Racing	Prize Giving Craning out of boats

6.2 Up to nine (9) races are scheduled. The intention is that there will be three races a day. However, at the discretion of the Race Committee a race may be brought forward, or moved back if circumstances require it. No more than 4 races will be sailed in one day. An additional race does not constitute a change to the schedule under SI 2

6.3 On Monday August 28th no warning signal will be made after 15:00.

6.4 All boats shall sail as one fleet.

## 7. CLASS FLAG

7.1 The class flag is Flag J.

## 8. RACING AREA

8.1 **Addendum A** shows the location of the racing areas including a guide to distance from WPNSA.

## 9. COURSES

9.1 The course to be sailed will be a windward-leeward format. The diagrams in **Addendum B** show the course, including the order in which marks are to be passed, and the side on which each mark is to be left.

9.2 No later than the warning signal for each race, the RC signal vessel will display the approximate magnetic bearing and distance to mark 1.

## 10. MARKS

10.1 Marks 1, 1A (offset), 2S /2P (gate), inflatable orange “dumpy” marks.

10.2 New marks, as provided in SI 11, inflatable blue “dumpy” marks with a black band.

10.3 Starting marks are RC vessels displaying orange flags.

10.4 Finish marks are RC vessels displaying blue flags.

## 11. OBSTRUCTIONS [DP,NP]

- 11.1 Boats shall keep more than 100 metres away from ships over 100 metres in length, ships at anchor or ships displaying Flag A (indicating divers in the water). These areas rank as obstructions.
- 11.2 The attention of all competitors, race management personnel and spectators afloat are drawn to the fact that Portland Harbour is a working port and that harbour regulations shall be observed. Any directions given by Portland Harbour Authority either in person or by VHF (CH 74) shall be complied with without delay. Failure to comply with this instruction may result in a penalty.
- 11.3 Only the Northern entrance shall be used in leaving or returning to Portland Inner Harbour, unless directed otherwise by an Official or Portland Harbour Authority Boat.
- 11.4 Boats shall not transit at any time through the RNSA moorings, which are to the left of the Marina exit when leaving the Marina.

## 12. THE START

- 12.1 The starting line will consist of two RC vessels.
- 12.2 To alert boats that a race will begin soon, orange starting line flags will be displayed with one long sound signal on the RC signal vessel marking the line for a minimum of 5 minutes before the warning signal is displayed.
- 12.3 Individual and General Recall flags will be displayed on the RC signal vessel in accordance with RRS 29 and may be displayed by other starting line boat as a courtesy. This changes RRS 29.1 and RRS 29.2.
- 12.4 Boats subject to individual recall under RRS 29.1 or boats breaking RRS 30.3 (*U Flag Rule*) or RRS 30.4 (*Black Flag Rule*) will be broadcast on the VHF Channel using bow numbers as a courtesy.
- 12.5 In the event of a General Recall or abandonment after the start during a RRS 30.4 (*Black Flag Rule*) start, the RC shall broadcast on the VHF Channel and display the bow number of any boat violating RRS 30.4 before the next warning signal. This changes RRS 30.4.
- 12.6 The RC will attempt to make the broadcasts described in SI 12.4 and 12.5. However, the timing of such a broadcast, the sequence of the broadcasts or the failure to make or hear the broadcasts shall not be grounds for granting redress. This changes RRS 62.1(a).
- 12.7 A boat that does not start within five (5) minutes after her starting signal will be scored Did Not Start (DNS) without a hearing. This change is added to RRS A5.1.

## 13. CHANGING THE NEXT LEG OF THE COURSE

- 13.1 To change the next leg of the course, the RC will lay a new mark (or move the finishing line) and remove the original mark as soon as practicable. When in a subsequent change a new mark is replaced, it will be replaced with the original mark.
- 13.2 When Mark 1 is replaced, Mark 1a will also be replaced with a matching mark as described in SI 10.2

## 14. THE FINISH

- 14.1 The finish line is between staffs displaying blue flags on RC vessels.

## 15. PENALTY SYSTEM

- 15.1 The One-Turn and the Two-Turns Penalty in RRS 44 are replaced with a One-Turn unless a rule of Part 2 was broken while in the zone around a mark other than a starting mark, in which case a Two-Turns Penalty applies.
- 15.2 Penalties while in the zone of the windward mark or on the offset leg shall be delayed and taken at the first reasonable opportunity on the leg after clearing the zone of the offset mark. This change is added to RRS 44.2.
- 15.3 A boat that has taken a penalty under RRS 31 or RRS 44.1 shall submit a completed penalty acceptance form on the online notice board within the protest time limit.
- 15.4 RRS Appendix T (Arbitration) applies.
- 15.5 The Jury may impose discretionary penalties other than disqualification for violations of RRS non-Part 2 rules. This SI does not apply to breaches of RRS 2, 28 or 31.
- 15.6 The Jury may impose discretionary penalties other than disqualification for violations of Class Rules, including the International J/70 Class Rules (J70CR) and the J/70 Equipment Regulations (J70ER). However, in no case shall the penalty for such a violation be less than a ten percent (10%) scoring penalty calculated pursuant to RRS 44.3(c). This changes RRS 64.6.

## 16. TIME LIMITS AND TARGET TIMES

- 16.1 The race time limit for each race is 120 minutes. The target time for each race is 50-60 minutes. Failure to meet the target time will not be grounds for a request for redress. This changes RRS 60.1(b).
- 16.2 Boats failing to finish within 20 minutes after the first boat sails the course and finishes within the race time limit will be scored Time Limit Expired (TLE) without a hearing, unless they subsequently retire, are penalised, or are given redress. The score for TLE is the number of finishers plus two points, but no worse than the score for DNF. This changes RRS 35 and is added to RRS A4, A5, and A10.
- 16.3 The RC will lower the finish line flags to indicate that the time limit has expired.

## 17. HEARING REQUESTS

- 17.1 Hearing request forms are available online at <https://yachtscoring.com/emenu.cfm?eID=15892>. Protests and requests for redress or reopening shall be delivered to the race office within the appropriate time limit.
- 17.2 The protest time limit each day is sixty (60) minutes after the RC signal vessel docks on that day. This time will be posted on the online Official Notice Board within fifteen (15) minutes after the RC signal vessel docks.
- 17.3 The second sentence of RRS 62.2 is replaced with: "If the request is based on an incident in the racing area, it shall be filed within the protest time limit for that day."
- 17.4 A notice of boats scored per RRS A5.1 will be posted on the Official Notice Board no later than fifteen (15) minutes after the RC signal vessel docks on that day. The deadline for a request for redress based on these scores is the protest time limit for that day. This changes RRS 62.2.
- 17.5 The time limit for a request for redress based on the outcome of a scoring inquiry is 30 minutes after that outcome has been posted. This changes RRS 62.2.
- 17.6 The Categorization Protest Time Limit (see World Sailing Regulation 22.5.1) is the protest time limit for the first racing day.
- 17.7 Penalty acceptance forms are available on the regatta website.
- 17.8 Notices will be posted no later than fifteen (15) minutes after the protest time limit each day on the Official Notice Board to inform competitors of hearings in which they are parties or named as witnesses. Hearings will be heard as soon as possible.
- 17.9 On the last day of the event, a request for reopening a hearing shall be delivered within the protest time limit if the requesting party was informed of the decision on the previous day or no later than 30 minutes after the requesting party was informed of the decision on that day. This changes RRS 66.2.
- 17.10 On the last day of the event, a request for redress based on a jury decision shall be delivered no later than 30 minutes after the decision was posted. This changes RRS 62.2.

## **18. SCORING**

- 18.1 Scoring shall be according to the Low Point Scoring System of RRS A2 and A4 as follows:
- (a) When fewer than four (4) races have been completed, a boat's series score shall be the total of her race scores;
  - (b) When four (4) or more races have been completed, a boat's series score shall be the total of her race scores excluding her worst score.
- 18.2 Three (3) races are required to constitute a championship.
- 18.3 Preliminary results will be posted on the event website as soon as possible after racing each day.
- 18.4 Competitors shall notify the RC of any scoring inquiry by filing a Scoring Inquiry Form available on the online notice board. The deadline to file a scoring inquiry is the protest time limit or thirty (30) minutes after the preliminary results have been posted for that day, whichever is later.

## **19. SAFETY REGULATIONS**

- 19.1 [DP] [NP] Prior to the warning signal of her first race each day, each boat shall check-in with the RC signal vessel in the starting area. Each boat shall pass close astern on starboard tack and hail her bow number. When a boat has been recognised, the RC will hail the boat's bow number.
- 19.2 [DP] [NP] A boat that retires from a race or leaves the racing area between races shall notify the RC as soon as possible using the VHF Channel.
- 19.3 [DP] [NP] A boat not leaving the marina for any of the day's racing shall inform the RC as soon as possible.
- 19.4 The penalty for breaking a rule in SI 19 shall be a twenty percent (20%) scoring penalty calculated pursuant to RRS 44.3(c) unless the Jury decides differently, applied without a hearing to a boat's first valid race of the day. This change is added to RRS A5.1.

## **20. REPLACEMENT OF CREW OR EQUIPMENT**

- 20.1 Substitution of competitors is not allowed without written approval of the Race Committee prior to racing on that day.
- 20.2 Repair, alteration, replacement, or substitution of damaged or lost equipment will not be allowed unless authorized before racing by the Race Committee.
- 20.3 Boats requesting approvals under SI 20 shall contact the Race Committee for instructions:
- (a) If off the water: by phone, text message (see SI 31) or Telegram (See Addendum D)
  - (b) If on the water: hailing on the VHF Channel.

## **21. EQUIPMENT AND MEASUREMENT CHECKS**

- 21.1 [DP] Pursuant to J70ER 4, a boat, sails or equipment may be inspected at any time for compliance with the Event Equipment Rules (see J70ER 2), IJ70CA Class Rules (J70CR), the NoR and these SIs. On the water, when instructed by a member of the RC, a boat shall proceed immediately to a designated area for inspection.
- 21.2 Bow numbers may be supplied and applied by the OA in accordance with the J70ER 6 and J70ER Appendix A as shown in Addendum C.
- 21.3 Bow numbers shall be displayed from the time they are applied by the OA through the end of the event. It is the responsibility of the competitor to ensure that the bow numbers remain on the boat and obtain replacements as necessary.

## **22. EVENT ADVERTISING**

- 22.1 [DP] [NP] Boats shall display any event advertising supplied by the OA, in accordance with World Sailing Regulation 20. If this rule is broken, World Sailing Regulation 20.9.2 applies.
- 22.2 [DP] [NP] Any required sponsor or event identification stickers, decals and flags shall be placed on the bow or boom, in the cockpit or on a shroud or stay as directed by the OA. They shall be displayed from the close of check-in through the end of the event. If required to be placed on the bow, they shall be placed immediately aft of the bow numbers. It is the responsibility of the competitor to ensure that the stickers remain on the boat and obtain replacements as necessary.

## 23. OFFICIAL VESSELS

[NP] Official vessels are marked as follows:

Category	Flag
Mark Laying Vessels	None
Press Vessels	Green flag with white Media
Safety	Numbered red

## 24. SUPPORT TEAMS

- 24.1 All Support Person Vessels (SPV) shall check-in/register with WPNSA Reception on arrival, prior to launching the vessel. On check-in they shall confirm the details of the driver and which boats they are supporting/coaching. All support boats are required to display an identification flag whenever on the water during the event. Flags will be assigned when registering and as per the NOR 17.3 a £50 cash deposit is required for the flag. The deposit will be returned when the flag is returned to WPNSA Reception at the end of the event.
- 24.2 [DP] [NP] Only registered Support Person Vessels (SPVs), including coach, press, private and spectator vessels that prominently display identification provided by the OA are allowed in the racing area. The person in charge of the competing boat(s) to which support vessels are attached shall acknowledge the presence of a support vessel on his check-in form and may pay the applicable fee on behalf of the support vessel.
- 24.3 [DP] [NP] All SPVs shall carry a working VHF radio capable of transmitting and receiving normal domestic and international channels, including the VHF Channel.
- 24.4 [DP] SPVs, and team leaders, coaches, and other support personnel, shall stay more than 150 meters to leeward of the starting line, leeward marks, and from any competing boats that are racing.
- 24.5 [DP] [NP] SPVs shall comply with any additional directions given by the OA, the RC or the Jury, including requests for assistance with rescues. Failure to comply may result in the accreditation being withdrawn and all access to the club facilities, grounds and docks being denied.
- 24.6 [DP] [NP] SPVs shall be kept in the places, both afloat and ashore, that they specify during check-in.
- 24.7 Operators of SPVs and all competitors are reminded that J70CR I.3 (Outside Assistance) is in effect. See NoR 1.

## 25. TRASH DISPOSAL

- 25.1 [DP] Rubbish shall be placed in the appropriate bins when the boats return to shore.

## 26. BERTHING

- 26.1 [DP] Boats shall be kept in their assigned places while in the harbour.

## 27. HAUL-OUT RESTRICTIONS

- 27.1 [DP] Boats shall not be hauled out during the event.

## 28. DIVING EQUIPMENT AND PLASTIC POOLS

- 28.1 [DP] Underwater breathing apparatus and plastic pools or their equivalent shall not be used around keelboats between the preparatory signal of the first race and the end of the last race of the event.

## 29. PRIZES

- 29.1 Prizes will be awarded as specified in the NoR.

### 30. RISK STATEMENT

- 30.1 Rule 3 of the Racing Rules of Sailing states: 'The responsibility for a boat's decision to participate in a race or to continue racing is hers alone.'
- 30.2 Sailing is by its nature an unpredictable sport and therefore inherently involves an element of risk. By taking part in the event, each competitor agrees and acknowledges that:
- a) They are aware of the inherent element of risk involved in the sport and accept responsibility for the exposure of themselves, their crew and their boat to such inherent risk whilst taking part in the event;
  - b) They are responsible for the safety of themselves, their crew, their boat and their property whether afloat or ashore;
  - c) They accept responsibility for any injury, damage or loss to the extent caused by their own actions or omissions;
  - d) Their boat is in good order, equipped to sail in the event and they are fit to participate;
  - e) The provision of a race management team, patrol boats and other officials and volunteers by the event organiser does not relieve them of their own responsibilities;
  - f) The provision of patrol boat cover is limited to such assistance, particularly in extreme weather conditions, as can be practically provided in the circumstances;
  - g) It is their responsibility to familiarise themselves with any risks specific to this venue or this event drawn to their attention in any rules and information produced for the venue or event and to attend any competitors briefing held for the event;

### 31. RACE OFFICIALS

Host Club Contact:

WPNSA, Osprey Quay, Portland, Dorset, UK. DT5 1SA

T: 01305 866000 [reception@wpnsa.org.uk](mailto:reception@wpnsa.org.uk)

Principal Race Officer:

Ian Bullock, IRO



# Addendum A RACING AREA

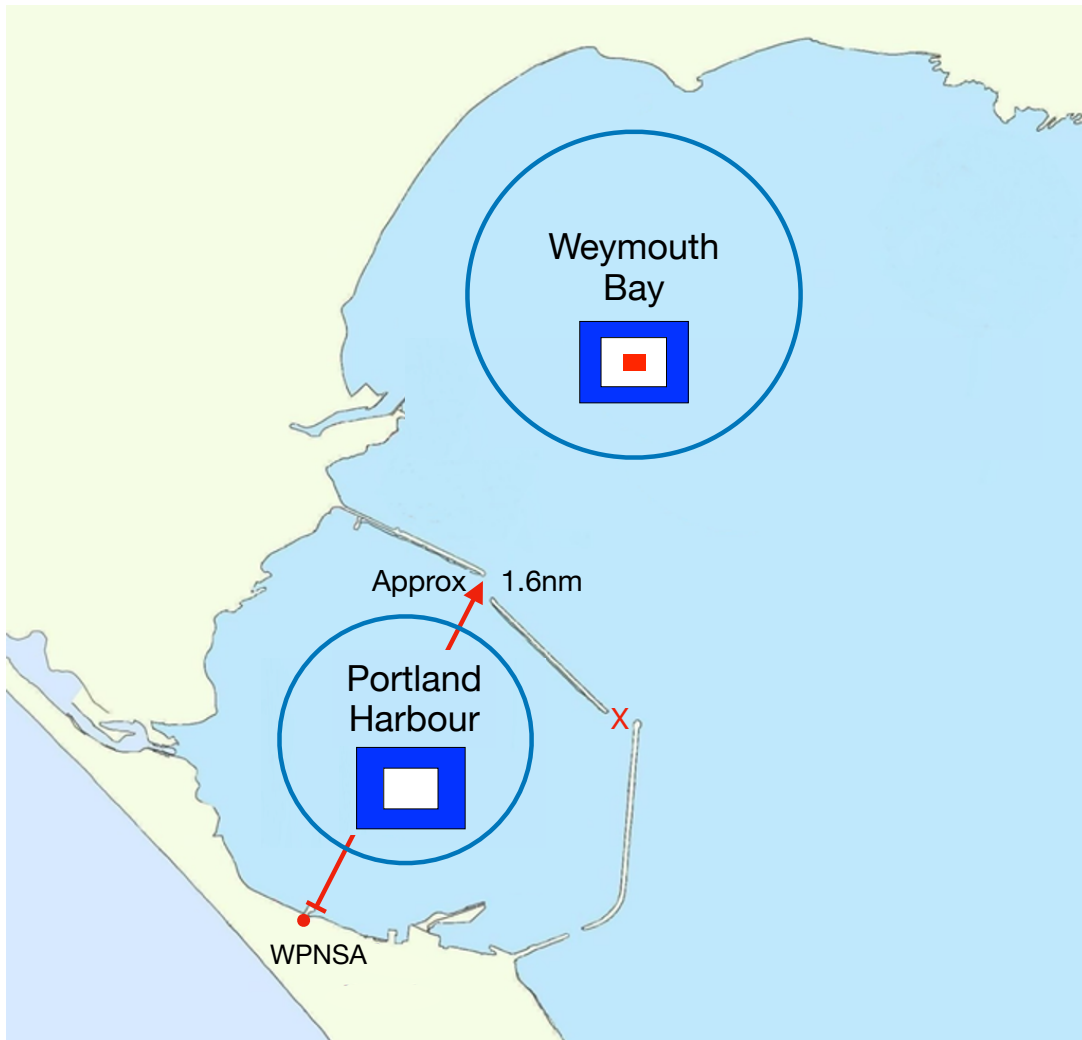

## Addendum B COURSES

<b>L</b>	<b>COURSE: WINDWARD / LEEWARD with spreader and downwind finish</b>
<b>Signal</b>	<b>Mark Rounding Order</b>
<b>L2</b>	Start - 1 - 1a - 2s/2p - 1 - 1a - Finish
<b>L3</b>	Start - 1 - 1a - 2s/2p - 1 - 1a - 2s/2p - 1 - 1a- Finish

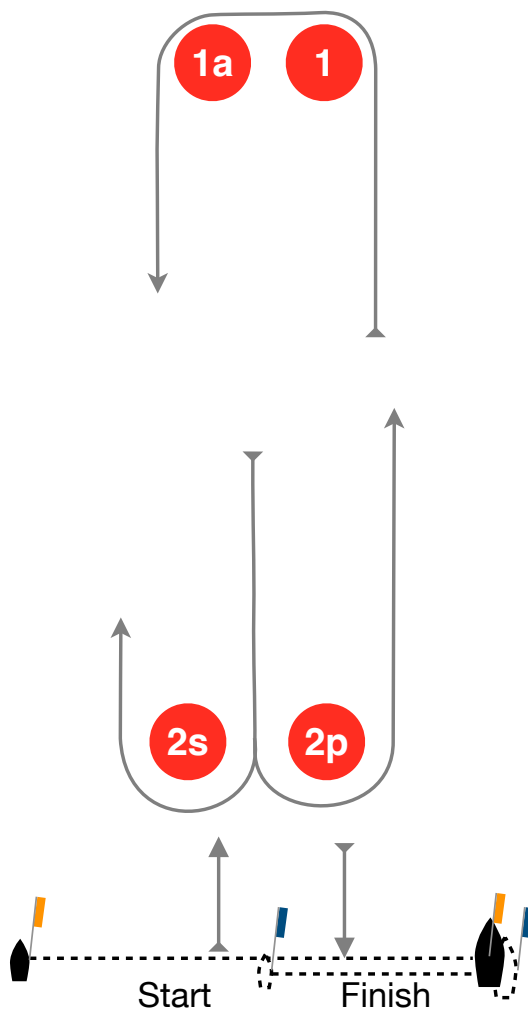

## Addendum C

### J/70 EQUIPMENT REGULATIONS Bow Number Positioning

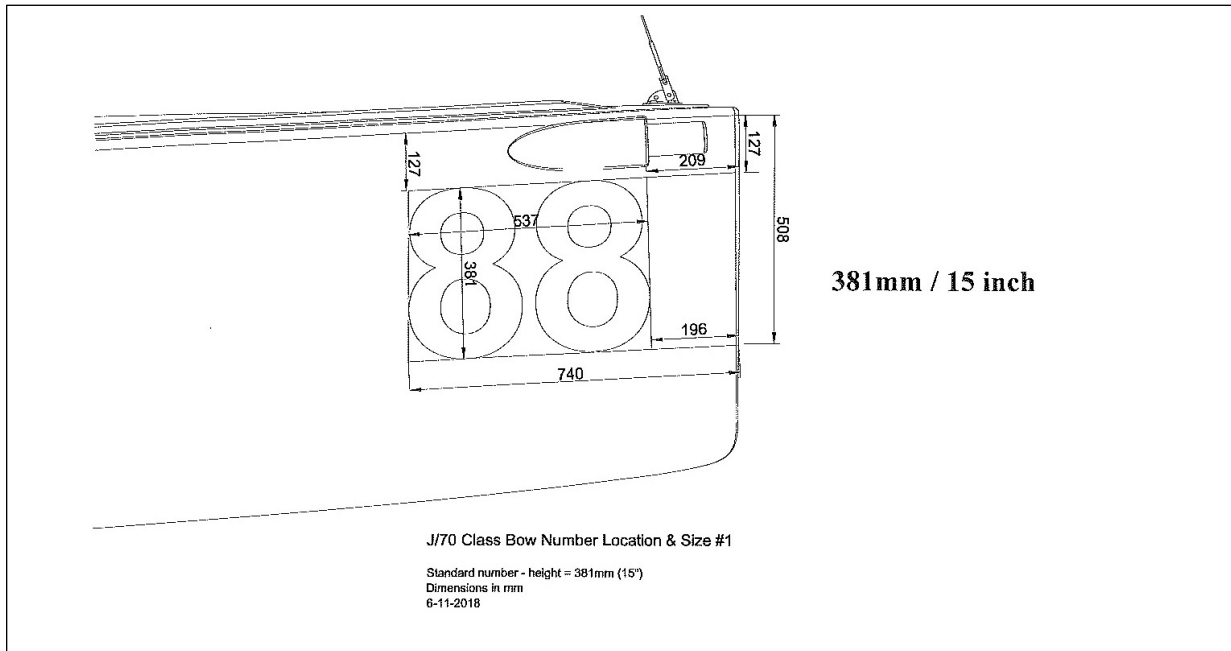

## Addendum D

### Official Regatta *Telegram* Group

In addition to the Official Notice Board, the Organising Authority may send messages to competitors and support persons via the Instant Messaging Application, Telegram.

Telegram is similar to WhatsApp but has better privacy (phone numbers are not public), allows larger groups people and allows new arrivals to see existing messages.

Please download Telegram for your Smart Phone and/or Laptop prior to the event from the links on <https://telegram.org>



Then join the groups below by following the link or scanning the QR codes:

**Broadcast:** Messages from the Organising Authority and Race Committee:

<https://t.me/+8tZ9rbhdOU5ZTA0>



**Queries:** Questions to the Organising Authority or Race Committee:

<https://t.me/+Hqq5Q1DQqhExN2M0>



The speed of answers may vary and may be sent via the broadcast group. Please use this facility as sparingly as possible and certainly not for chat or it will lose its effectiveness.