



J/70 NORTH AMERICAN CHAMPIONSHIP

RIVIERA NAYARIT, MEXICO

April 28-May 4, 2024



2024 J/70 North American Championship

April 28 – May 04, 2024

Vallarta Yacht Club (VYC) - Riviera Nayarit, Mexico

SAILING INSTRUCTIONS

Amendment #1 (posted 04/30/2024) – changes in bold red (SI 5.1, SI 11.6, SI 20.3, SI 23, Addendum A, Addendum C UF 3.4)

The Organizing Authority (OA) is the VYC and the International J/70 Class Association (IJ70CA).

Event Website: <https://www.yachtscoring.com/emenu.cfm?eID=16125>

See SI 29 for full contact information

The notation '[NP]' in a rule means that a boat may not protest another boat or request redress for a violation of that rule. This changes RRS 60.1.

1. RULES

NoR 1 contains a list of rules for this event. Competitors are reminded to take note of these.

2. CHANGES TO SAILING INSTRUCTIONS

Any change to the SIs will be posted before 0900 on the day it will take effect, except that any change to the schedule of races will be posted by 2000 on the day before it will take effect.

3. COMMUNICATION

3.1 Notices to competitors will be posted on the Official Notice Board located on the YachtScoring event site listed above. Unofficial but informative messages may be made on the "J/70 NAs" WhatsApp group (**Addendum E** contains a link and QR code to join that group).

3.2 The race office is located in the VYC conference room.

3.3 Any questions regarding the NoR or these SIs shall be submitted in writing to the Race Committee (RC). The questions and any answers will be posted as in SI 3.1.

3.4 A competitors' briefing will be held each race day at 1100 at the VYC clubhouse.

3.5 On the water, the RC intends to monitor and communicate with competitors on VHF radio channel 69 ('the VHF Channel'). Failure of the RC to broadcast, mistaken broadcasts, or failure of a competitor to receive this information will not be grounds for a request for redress. This changes RRS 60.1(b).

3.6 [NP] [DP] Boats shall use the radio to report retirement from racing and may use the radio to request or provide assistance in an emergency.

3.7 [DP] Except as provided in SI 3.6, a boat shall not make voice or data transmissions while racing and shall not receive voice or data communication that is not available to all boats. [DP]

4. CODE OF CONDUCT

- 4.1 [DP] Competitors and support persons shall comply with reasonable requests from race officials.
- 4.2 [DP] Competitors and support persons shall handle any equipment if provided by the organizing authority with care, seamanship, in accordance with any instructions for its use and without interfering with its functionality.

5. SIGNALS MADE ASHORE

- 5.1 Signals made ashore will be displayed on the flagpole **located on the second floor outside deck at the VYC Clubhouse by the launch ramp at the public dock.**
- 5.2 When flag AP is displayed ashore, “1 minute” is replaced with “not less than sixty (60) minutes” in The Racing Rules of Sailing (RRS) Race Signal AP.

6. SCHEDULE AND FORMAT OF RACES

6.1 Race Schedule

Day	Races Planned	First Warning Signal
Tuesday, April 30	1 or more practice race(s)	1430
Wednesday, May 01	3 races	1300
Thursday, May 02	3 races	1300
Friday, May 03	3 races	1300
Saturday, May 04	2 races	1300 (no warning signal after 1700)

- 6.2 Up to eleven (11) races are scheduled with three (3) races per day on Wednesday-May 01 through Saturday-May 04. A maximum of three (3) races may be sailed in one day. The RC, at its discretion, may run fewer total races.
- 6.3 The scheduled time of the first warning signal each day is 1300. Subsequent races will start as soon as practicable.
- 6.4 On Saturday-May 04, no warning signal will be made after 1700 local time. In the case of one or more general recall(s) when the initial warning signal was made prior to 1700, the RC may display subsequent warning signals after that time. This exception will not apply for a race that is postponed or abandoned.
- 6.5 All boats shall sail as one fleet.

7. CLASS FLAG

The class flag is a blue J/70 logo on a white background or numeral pennant #1.

8. RACING AREA

Addendum A shows the location of the racing area.

9. COURSES

- 9.1 The course to be sailed will be a windward-leeward format. The diagrams in **Addendum B** show the course, including the order in which marks are to be passed, and the side on which each mark is to be left.
- 9.2 No later than the warning signal for each race, the RC signal vessel will use placards to identify the approximate magnetic bearing and distance to the first weather mark.
- 9.3 Courses will not be shortened using flag “S”. This changes RRS 32. However, legs of the course may be shortened (or lengthened) pursuant to RRS 33.

10. MARKS

- 10.1 Mark 1 is an orange tetrahedron.
- 10.2 Mark 1A (offset) is a green tetrahedron.
- 10.3 Marks 2S /2P (leeward gate) are orange tetrahedrons.
- 10.4 A new weather mark, as provided in SI 12, is a yellow tetrahedron with an associated green tetrahedron offset mark.
- 10.5 Starting marks are RC vessels.
- 10.6 Finishing marks are RC vessels.

11. THE START

- 11.1 The starting line is between staffs displaying orange flags on the starboard RC signal vessel and the port-end RC line vessel. Sounds and visual signals will be made only on the starboard-end RC signal vessel.
- 11.2 To alert boats that a race will begin soon, orange starting line flags will be displayed with one long sound signal on the RC signal vessel marking the line for a minimum of 5 minutes before the warning signal is displayed.
- 11.3 Individual and General Recall flags will be displayed on the RC signal vessel in accordance with RRS 29 and may be displayed by other starting line boats as a courtesy. This changes RRS 29.1 and RRS 29.2.
- 11.4 Boats subject to individual recall under RRS 29.1 or boats breaking RRS 30.3 (*U Flag Rule*) or RRS 30.4 (*Black Flag Rule*) will be broadcast on the VHF Channel using bow numbers as a courtesy.
- 11.5 In the event of a General Recall or abandonment after the start during a RRS 30.4 (*Black Flag Rule*) start, the RC shall broadcast on the VHF Channel and display the bow number of any boat violating RRS 30.4 before the next warning signal. This changes RRS 30.4.
- 11.6 The RC will attempt to make the broadcasts described in ~~SI 11.3 and~~ SI 11.4 **and SI 11.5**. However, the timing of such a broadcast, the sequence of the broadcasts or the failure to make or hear the broadcasts shall not be grounds for granting redress. This changes RRS 62.1(a).
- 11.7 A boat that does not start within five (5) minutes after her starting signal will be scored Did Not Start (DNS) without a hearing. This change is added to RRS A5.1.

12. CHANGING THE NEXT LEG OF THE COURSE

To change the next leg of the course, the RC will lay a new mark (or move the finishing line) and remove the original mark as soon as practicable. When in a subsequent change a new mark is replaced, it will be replaced with the original mark.

13. THE FINISH

The finish line is between staffs displaying blue flags on RC vessels.

14. PENALTY SYSTEM

- 14.1 The first sentence of RRS 44.1 is changed to "A boat may take a One-Turn Penalty when she may have broken one or more rules of Part 2 in an incident while racing, except that when she may have broken a rule of Part 2 while in the zone around a mark other than a starting mark, her penalty shall be a Two-Turns Penalty."
- 14.2 Penalties incurred while in the zone of the windward mark or on the offset leg shall be delayed and taken at the first reasonable opportunity on the downwind leg. This change is added to RRS 44.2.
- 14.3 Appendix UF (Umpired Fleet Racing) is in effect and replaced in its entirety as stated in **Addendum C**.
- 14.4 Jury vessels may be positioned anywhere on the course area. Their position at any time will not be grounds for a request for redress. This changes RRS 60.1(b).
- 14.5 A boat that has taken a penalty under RRS 31 or RRS 44.1 shall submit a completed penalty acceptance form at the jury desk or regatta website within the protest time limit.
- 14.6 RRS Appendix T (Arbitration) applies.
- 14.7 The IJ may impose discretionary penalties other than disqualification for violations of RRS non-Part 2 rules. This SI does

not apply to breaches of RRS 2, 28 or 31.

- 14.8 The IJ may impose discretionary penalties other than disqualification for violations of Class Rules, including the International J/70 Class Rules (J70CR) and the J/70 Equipment Regulations (J70ER). However, in no case shall the penalty for such a violation be less than a ten percent (10%) scoring penalty calculated pursuant to RRS 44.3(c). This changes RRS 64.6.

15. TIME LIMITS AND TARGET TIMES

- 15.1 The race time limit for each race is 120 minutes. The target time for each race is 60 minutes. Failure to meet the target time will not be grounds for a request for redress. This changes RRS 60.1(b).
- 15.2 Boats failing to finish within 20 minutes after the first boat sails the course and finishes within the race time limit will be scored Time Limit Expired (TLE) without a hearing, unless they subsequently retire, are penalized, or are given redress. The score for TLE is the number of finishers plus two points, but no worse than the score for DNF. This changes RRS 35 and is added to RRS A4, A5, and A10.
- 15.3 The RC will lower the finish line flags with one sound to indicate that the time limit has expired.

16. HEARING REQUESTS

- 16.1 The jury desk will be located outside of the the VYC Conference room. The hearing room will be located in the VYC Conference room.
- 16.2 The protest time limit each day is sixty (60) minutes after the RC signal vessel docks on that day. This time will be posted on the Official Notice Board and at the jury desk within fifteen (15) minutes after the RC signal vessel docks.
- 16.3 The second sentence of RRS 62.2 is replaced with: "If the request is based on an incident in the racing area, it shall be filed within the protest time limit for that day."
- 16.4 A notice of boats scored per RRS A5.1 and SI **Addendum C** each day will be posted on the Official Notice Board and at the jury desk no later than fifteen (15) minutes after the RC signal vessel docks on that day. The deadline for a request for redress based on these scores is the protest time limit for that day. This changes RRS 62.2.
- 16.5 The time limit for a request for redress based on the outcome of a scoring inquiry is 30 minutes after that outcome has been posted. This changes RRS 62.2.
- 16.6 The Categorization Protest Time Limit (see World Sailing Regulation 22.5.1) is the protest time limit for the first racing day.
- 16.7 Hearing request forms are available at the jury desk or on the regatta website.
- 16.8 Penalty acceptance forms are available at the jury desk or on the regatta website.
- 16.9 Notices will be posted no later than fifteen (15) minutes after the protest time limit each day on the Official Notice Board and at the jury desk to inform competitors of hearings in which they are parties or named as witnesses. Hearings will be heard as soon as possible.
- 16.10 On the last day of the event, a request for reopening a hearing shall be delivered within the protest time limit if the requesting party was informed of the decision on the previous day or no later than 30 minutes after the requesting party was informed of the decision on that day. This changes RRS 66.2.
- 16.11 On the last day of the event, a request for redress based on a jury decision shall be delivered no later than 30 minutes after the decision was posted. This changes RRS 62.2.

17. SCORING

- 17.1 Scoring shall be according to the Low Point Scoring System of RRS A2 and A4 as follows:
- When fewer than five (5) races have been completed, a boat's series score shall be the total of her race scores;
 - When five (5) or more races have been completed, a boat's series score shall be the total of her race scores excluding her worst score.
- 17.2 Three (3) races are required to constitute a championship.
- 17.3 Preliminary results will be posted on the event website as soon as possible after racing each day.

17.4 Competitors shall notify the RC of any scoring inquiry by filing a Scoring Inquiry Form available at the jury desk or the regatta website. The deadline to file a scoring inquiry is the protest time limit or thirty (30) minutes after the preliminary results have been posted for that day, whichever is later.

18. SAFETY REGULATIONS

18.1 [DP] [NP] Prior to the warning signal of her first race each day, each boat shall check-in with the RC signal vessel in the starting area. Each boat shall pass close astern on starboard tack and hail her bow number. When a boat has been recognized, the RC will hail the boat's bow number.

18.2 [DP] [NP] A boat that retires from a race or leaves the racing area between races shall notify the RC as soon as possible using the VHF Channel.

18.3 [DP] [NP] A boat not leaving the harbor for any of the day's racing shall inform the RC as soon as possible.

18.4 The penalty for breaking a rule in SI 18 shall be a twenty percent (20%) scoring penalty calculated pursuant to RRS 44.3(c) unless the Jury decides differently, applied without a hearing to a boat's first valid race of the day. This change is added to RRS A5.1.

19. BOW NUMBERS [NP]

19.1 Bow numbers will be supplied and applied by the OA in accordance with the J70ER 6 and J70ER Appendix A as shown in **Addendum D**.

19.2 Bow numbers shall be displayed from the time they are applied by the OA through the end of the event. It is the responsibility of the competitor to ensure that the bow numbers remain on the boat and obtain replacements as necessary.

20. REPLACEMENT OF CREW OR EQUIPMENT

20.1 Substitution of competitors is not allowed without written approval of the event Technical Committee prior to racing on that day.

20.2 Repair, alteration, replacement, or substitution of damaged or lost equipment will not be allowed unless authorized before racing by the event Technical Committee pursuant to J70ER 10.

20.3 Boats requesting approvals under SI 20 shall contact the event Technical Committee for instructions:

(a) If off the water: by phone, text message, or WhatsApp (see SI 29~~29~~ for contact information);

(b) If on the water: hailing on the VHF Channel.

21. EQUIPMENT AND MEASUREMENT CHECKS

[DP] Pursuant to J70ER 4, a boat, sails or equipment may be inspected at any time for compliance with the Event Equipment Rules (see J70ER 2), IJ70CA Class Rules (J70CR), the NoR and these SIs. On the water, when instructed by a member of the RC or event Technical Committee, a boat shall proceed immediately to a designated area for inspection.

22. EVENT ADVERTISING

22.1 [DP] [NP] Boats shall display any event advertising supplied by the OA, in accordance with World Sailing Regulation 20. If this rule is broken, World Sailing Regulation 20.9.2 applies.

22.2 [DP] [NP] Any required sponsor or event identification stickers, decals and flags shall be placed on the bow or boom, in the cockpit or on a shroud or stay as directed by the OA. They shall be displayed from the close of check-in through the end of the event. If required to be placed on the bow, they shall be placed immediately aft of the bow numbers. It is the responsibility of the competitor to ensure that the stickers remain on the boat and obtain replacements as necessary.

23. OFFICIAL VESSELS

[NP] Official vessels may be marked as follows:

Category	Flag
Jury Vessels	White flag with "JURY" in black
Safety Vessels	White flag with a red "+"
Technical Committee (Measurement)	White flag with "M" in black
Press Vessels	White flag with "PRESS" in black

24. SUPPORT TEAMS

- 24.1 [DP] [NP] Only registered Support Person Vessels (SPVs), including coach, press, private and spectator vessels that prominently display identification provided by the OA are allowed in the racing area. The person in charge of the competing boat(s) to which support vessels are attached shall acknowledge the presence of a support vessel on his check-in form and may pay the applicable fee on behalf of the support vessel.
- 24.2 [DP] [NP] All SPVs shall carry a working VHF radio capable of transmitting and receiving normal domestic and international channels, including the VHF Channel.
- 24.3 [DP] SPVs, and team leaders, coaches, and other support personnel, shall stay more than 150 meters to leeward of the starting line, leeward marks, and from any competing boats that are racing.
- 24.4 [DP] [NP] SPVs shall comply with any additional directions given by the OA, the RC or the Jury, including requests for assistance with rescues. Failure to comply may result in the accreditation being withdrawn and all access to the club facilities, grounds and docks being denied.
- 24.5 [DP] [NP] SPVs shall be kept in the places, both afloat and ashore, that they specify during check-in.
- 24.6 Operators of SPVs and all competitors are reminded that J70CR I.3 (Outside Assistance) is in effect. See NoR 1.

25. TRASH DISPOSAL

[DP] Trash shall be placed in the appropriate containers when the boats return to shore.

26. BERTHING

[DP] Boats shall be kept in their assigned places while in the harbor.

27. PRIZES

Prizes will be awarded as specified in the NoR.

28. RISK STATEMENT

Competitors participate in the event entirely at their own risk. See RRS 3, Decision to Race. By participating in the event, each competitor agrees to release the race organizers (organizing authority, host yacht club, race committee, protest committee, sponsors, and any others acting in an official capacity for the event) from any and all liability associated with such competitor's participation in the event to the fullest extent permitted by law.

29. RACE OFFICIALS

Host Club Primary Contact:	Ernesto Gutierrez Ibarra	+52 333-954-4002	
Event Chair:	Linda Green	+52 322-181-6749	Greenlr01@gmail.com
IJ70CA Class Executive:	Christopher Howell	+1 440-796-3100	howell@j70classoffice.com
Principal Race Officer:	Chip Till	+1 843-556-6554	chiptill5351@gmail.com
Jury Chairman:	Stephen Wrigley	+1 714-697-0176	wrigley.s@yahoo.com
IJ70CA Technical Chair:	Mark Foster	+1 361-816-9801	mfooster1053@gmail.com
Chief Equipment Inspector:	Alex Finsterbusch		alexfinsterbusch@gmail.com
Boat and Trailer Storage:	Rodolfo Trejo	+52 322-134-5294	

Addendum A RACING AREA



Addendum B COURSES

COURSE "W" - WINDWARD/LEEWARD

1 - 1A - 2S/2P - 1 - 1A - FINISH

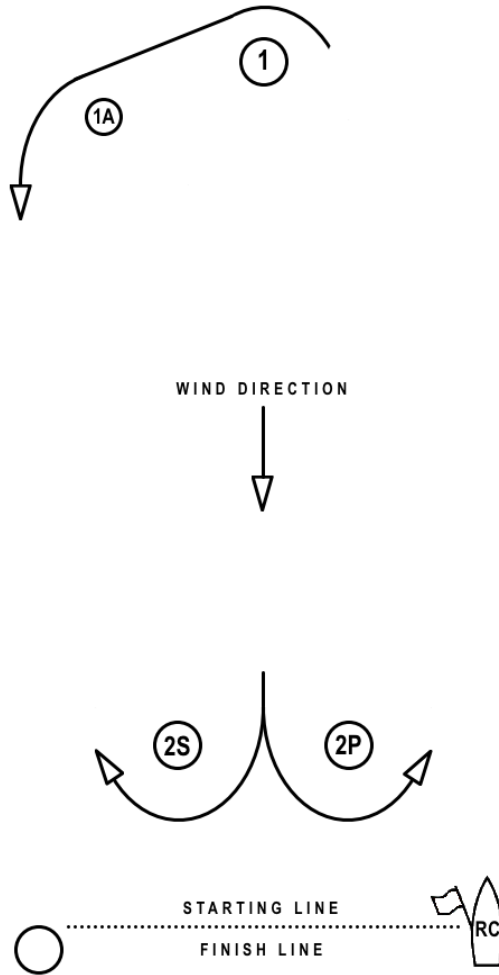

Addendum C

APPENDIX UF - UMPIRED FLEET RACING: J70 Edition - Version: 4.23.24A

Umpired fleet races shall be sailed under The Racing Rules of Sailing as changed by this appendix. Races shall be umpired. The rule changes in UF1 have been approved by World Sailing under Regulation 28.1.5(b) on the condition that only the provided options are used. This appendix applies only when it is referred to in the Notice of Race and made available for all competitors.

UF1 CHANGES TO THE DEFINITIONS, THE RULES OF PART 1 AND 2, AND RULE 70

UF1.1 Add to the definition *Proper Course*: 'A boat taking a penalty or maneuvering to take a penalty is not sailing a *proper course*.'

UF1.2 Add new rule 7 to Part 1:

7 LAST POINT OF CERTAINTY

The umpires will assume that the state of a boat, or her relationship to another boat, has not changed, until they are certain that it has changed.'

UF1.3 SPARE

UF1.4 When rule 20 applies, the following arm signals are required in addition to the hails:

- (a) for *room* to tack, repeatedly and clearly pointing to windward; and
- (b) for 'You tack', repeatedly and clearly pointing at the other boat and waving the arm to windward.

UF1.5 Rule 70 is deleted.

UF1.6 SPARE

UF2 CHANGES TO OTHER RULES

UF2.1 SPARE

UF3 ON WATER PROTESTS AND PENALTIES

UF3.1 In this appendix, 'a penalty' will mean the following:

A One-Turn Penalty taken in accordance with rule 44.2.

UF3.2 TAKING PENALTIES

- a. The first sentence of rule 44.1 is changed to: 'A boat may take a penalty when she may have broken one or more of the rules of RRS Part 2 in an incident while racing (except rule 14 when she has caused damage or injury), rule 31, rule 42 or Class rule C9.4 and C3.3. However, when she may have broken a rule of Part 2 of RRS while in the zone around a mark, other than a starting mark, or the RRS 20 in any area of the course, her penalty shall be a Two-Turns Penalty. When she may have broken a rule of Part 2 and rule 31 in the same incident, she need not take the penalty for breaking rule 31.
- b) A boat shall not take any penalties while in the zone of a mark, other than starting/finishing marks, or on the offset leg in which case the penalty shall be delayed and taken as soon as possible on the downwind leg. This changes rule RRS44.2

UF3.3 On the Water Protests by Boats and Penalties

- (a) While racing, a boat may protest another boat under a rule of Part 2 (except rule 14) or under rule 31 or rule 42; however, a boat may only protest under a rule of Part 2 for an incident in which she was involved. To do so she shall hail 'Protest' and conspicuously display a red flag at the first reasonable opportunity for each. The red flag shall be positioned on the rope between the boom and the upper mainsail sheet block. The use of any other flag shall not be valid for protest purposes. She shall retract the flag before, or at the first reasonable opportunity after a boat involved in the incident has taken a penalty voluntarily or after an umpire's decision. This changes RRS61.1(a).
- (b) A boat is not entitled to a hearing unless the umpire signals in accordance with UF3.5(d), a blue flag, or there is no umpire response to the protest.
- (c) An umpire may penalize any boat that broke a rule and was not exonerated unless the boat took a penalty voluntarily.

UF3.4 Penalties and Protests Initiated by an Umpire

- (a) When a boat
 - (1) breaks rule 31 and does not take a penalty,
 - (2) breaks rule 42 or UF3.2(b),
 - (3) gains an advantage despite taking a penalty,
 - (4) deliberately breaks a rule,
 - (5) commits a breach of sportsmanship,
 - (6) sails in a manner such that it is reasonable to predict that significant damage or injury could possibly result.
 - (7) fails to take a penalty when required to do so by an umpire,
 - (8) breaks Class Rule C9.4 (Bowsprit), or
 - (9) breaks Class Rule C3.3 (Crew Positioning),

an umpire may penalize her without a protest by another boat. The umpire may impose a penalty or more, each signaled in accordance with rule UF3.5(b) or disqualify her under rule UF3.5(c), or report the incident to the protest committee for further action. If a boat is penalized under rule UF3.4(a)~~(6)~~(7) for not taking a penalty or taking a penalty incorrectly, the original penalty is cancelled.

- (b) An umpire who decides, based on his own observation or a report received from any source, that a boat may have broken a rule, other than a rule listed in rule UF3.3(a), may inform the protest committee for its action under rule 60.3. However, he will not inform the protest committee of an alleged breach of rule 14 unless there is damage or injury.
- (c) A boat shall not take any penalties while in the zone of a mark, other than a starting/finishing marks, or on the offset leg. In the last case the penalty shall be delayed and taken as soon as possible on the downwind leg. This changes rule 44.2.

UF3.5 Umpire Signals

An umpire will signal a decision as follows:

- (a) A green and white flag with one long sound means 'No penalty.'
- (b) A red flag with one long sound means 'a penalty is imposed as per UF3.3(c). A red flag with two long sounds means the penalty will be two turns. The umpire will hail or signal to identify each such boat.
- (c) A black flag with one long sound means 'A boat is disqualified.' The umpire will hail or signal to identify the boat disqualified.

- (d) A blue flag with one long sound signal means “The umpires do not have the facts required to make a decision”.
- (e) Rule 43.1(a) is changed so that the provision for exonerating a boat may be applied by the umpires without a hearing, and it takes precedence over any conflicting sailing instruction.

UF3.6 Imposed Penalties

- (a) A boat penalized under rule UF3.5(b) shall take a penalty.
- (b) A boat disqualified under rule UF3.5(c) shall promptly leave the course area.

UF4 RACE COMMITTEE ACTIONS

UF4.1 At the end of the race the RC will promptly display flag B with one sound. Flag B will be displayed for at least two minutes and then removed with one sound.

UF5 PROTESTS; REQUESTS FOR REDRESS OR REOPENING; APPEALS; OTHER PROCEEDINGS

UF5.1 No proceedings of any kind may be taken in relation to any action or non-action by an umpire.

UF5.2 Spare

UF5.3 A boat intending to

- (a) protest another boat under a rule of Part 2 or rule 31 or 42 when an umpire has either responded after the incident with a blue flag or has not responded, or protest for a breach of any other rule.
- (b) protest another boat under rule 14 if there was contact that caused damage or injury, or despite taking a penalty gained a significant advantage, or
- (c) request redress based on an incident in the racing area

shall keep the protest flag displayed, when required, until she has informed the RC before, in case of retirement, or during the display of the “B” flag by hail or VHF call.

UF5.4 The time limit defined in rule UF5.3 also applies to protests under rule UF5.9, UF5.10 and UF5.11 when such protests are permitted. The protest committee shall extend the time limit if there is good reason to do so.

UF5.5 The race committee will promptly inform the protest committee about any protests or requests for redress made under rule UF5.3.

UF5.6 The third sentence of rule 61.1(a) is deleted when UF3.5(a) to (c) apply.

UF5.7 The first three sentences of rule 64.2 are changed to: ‘When the protest committee decides that a boat that is a *party* to a protest hearing has broken a rule, it may impose penalties other than disqualification, and may make any other scoring arrangement it decides is equitable. If a boat has broken a *rule* when not *racing*, the protest committee shall decide whether to apply any penalty to the race sailed nearest in time to that of the incident or make some other arrangement.’

UF5.8 Hearings

- (a) When Appendix T will be applied on the water no document will be produced by the parties and by the Arbitrator. Decision to accept a post race penalty and/or to withdraw a protest will be final and no further action shall be permitted.
- (b) Protests and requests of for redress reported to the race committee during the flag B period shall be lodged filed within the protest time limit. following the procedure as per SIs 16.

UF5.9 The race committee will not protest a boat except under rule 28 and 31.

- UF5.10** The protest committee may protest a boat under rule 60.3. However, it will not protest a boat for breaking rule UF3.6, a rule listed in rule UF3.3 (a), or rule 14 unless there is damage or injury.
- UF5.11** The technical committee will only protest a boat under rule 60.4 when it decides that a boat or personal equipment does not comply with the class rules, rule 50, or the rules in the equipment regulations of the event, if such exist. In such a case, the technical committee shall protest.

Addendum D

J/70 EQUIPMENT REGULATIONS Appendix A: Bow Number Positioning

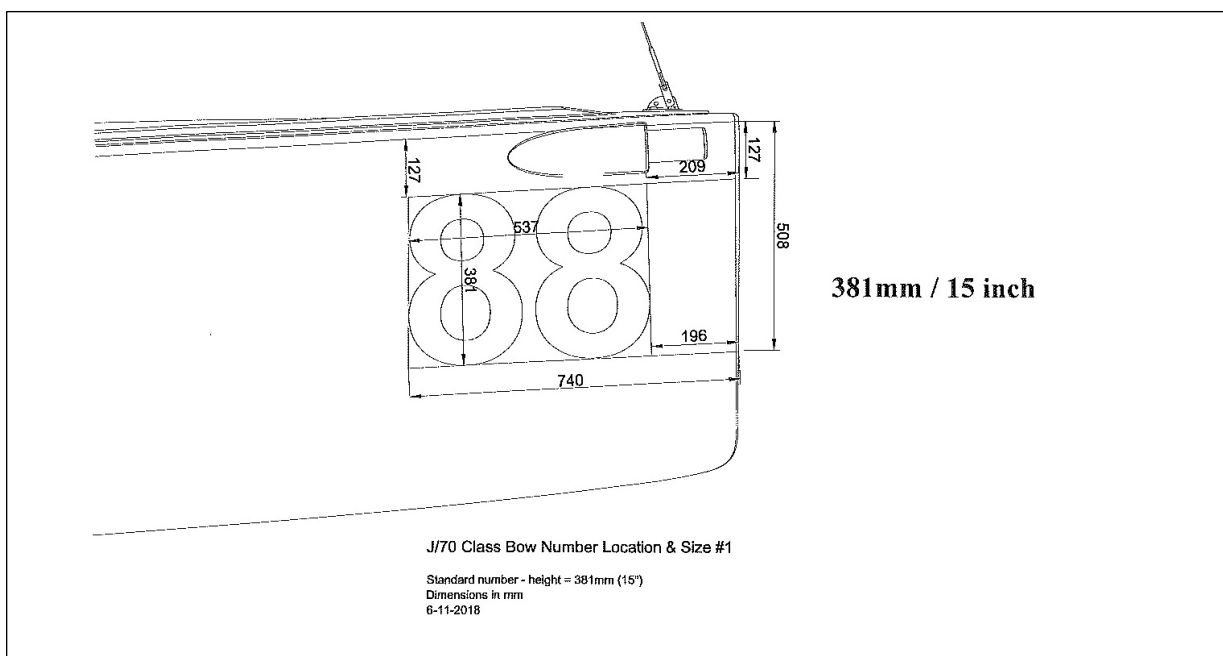

Addendum E

Regatta *WhatsApp* Group Link and QR Code

<https://chat.whatsapp.com/FhdWYd0MxvjAX4klecvZ35>

