

2017 Star North American Championship

Eastern Yacht Club, Marblehead, MA
September 5 - 10, 2017

SAILING INSTRUCTIONS

The Organizing Authority (OA) is Eastern Yacht Club (EYC)
In conjunction with the
International Star Class Yacht Racing Association (ISCYRA).
The host fleets are the Boston Harbor and Cape Ann Star Fleets.

1. Rules

- 1.1 The regatta will be governed by the *rules* as defined in *The Racing Rules of Sailing* (RRS) and the Rules of the International Star Class (STCR).
- 1.2 RRS Appendix P will apply. RRS Appendix P1.2 is changed to permit the hail of a protested boat to be by either sail number or bow number.
- 1.3 Only US Sailing Prescriptions RRS 40, 60.3, 61.4, 67, 70.5 and 76.1 and 88 will apply. This changes NOR 1.4. Addendum #1 to these SIs contains the complete text of these prescriptions. See SI 22.
- 1.4 Boats may carry VHF radios for purposes of safety and for receiving race committee communication, including notification of OCS boats (see SI 12). No other communication devices may be used.
- 1.5 RRS 44.1 and P2.1 are changed to replace “ Two-Turns Penalty” with “One-Turn Penalty”.

2. Notices to Competitors

Notices to competitors will be posted on the official notice board located in the EYC Sailing Center, located on the glass wall of the race committee office.

3. Crew Weight

Crews must comply with STCR 31.1.3 at all times.

4. Changes to the Sailing Instructions

Changes in the Sailing Instructions will be approved by the Protest Committee and the Organizing Authority and will be posted before 0800 hours on the day they will take effect, except that any change in the schedule of races will be posted by 2000 hours on the day before it will take effect.

5. Signals Made Ashore

5.1 Signals made ashore will be displayed on the Casey Flagpole, directly across the street from the Eastern Yacht Club.

5.2 When flag "AP" is displayed ashore, '1 minute' is replaced with 'not less than one hour' in the race signal AP.

6. Schedule of Races

6.1 Registration, Measurement, Crew Weigh-in, and Opening Ceremony:

Tuesday	September 5	0900 - 1600	Registration - EYC
Wednesday	September 6	0900 - 1600	Registration - EYC
Wednesday	September 6	1130	Skipper's Meeting
Wednesday	September 6	1800	Opening Ceremony
Thursday	September 7	0730-0800	Weigh-in Only

6.2 Schedule of Races:

Wednesday	September 6	1400	Practice Race
Thursday	September 7	1100	First Warning Signal No more than 3 races scheduled
Friday	September 8	1100	First Warning Signal No more than 3 races scheduled
Saturday	September 9	1100	First Warning Signal No more than 3 races scheduled
Sunday	September 10	1100	First Warning Signal No more than 3 races scheduled
Sunday	September 10	1400	No Initial Warning Signal After This Time

6.3 Eight races are scheduled.

7. Class Flag

The Class Flag will be the Star Class logo flag.

8. Racing Area

8.1 Racing will be conducted in the waters off Marblehead, MA, either in Mass Bay or Salem Sound.

8.2 Racing will primarily take place in Mass Bay; a change to Salem Sound will be signaled by raising code flag 'C', with one sound, on the Casey Flagpole before 0900 on the day it will take effect.

8.3 A chart of the racing area(s) will be posted on the glass wall in the sailing center.

9. Courses

9.1 Course 0, Course 1, Course 3, and Course 4 may be used. Diagrams are included in Appendix A.

9.2 The approximate compass bearing from Mark 3 (or Marks 3S and 3P) to Mark 1 will be displayed in the forward rack on the Signal Boat prior to or with the Warning Signal.

9.3 The courses will not be shortened. This changes RRS 32.

9.4 RRS 33(b) is deleted.

10. Marks

10.1 Mark 1 will be a yellow tetrahedron.

10.2 If used, a 'leeward gate' will consist of a pair of yellow tetrahedrons.

10.3 At any mark beginning a downwind leg on Course 0 or 1, the Race Committee may set an offset mark, which will be an orange tetrahedron. In that case, boats shall pass both Mark 1 and the offset mark to port. For Courses 3 and 4 the offset mark will be an orange tetrahedron.

10.4 A new mark will be a pink tetrahedron. In the event of a change of course, an offset mark may be used and it will be the same color as the new mark.

10.5 The finishing mark will be a green tetrahedron.

11. Check In

Prior to the first Warning Signal of the first race a boat sails each day, she shall sail past the stern of the Race Committee signal boat to be recorded. Boats not complying with this instruction will receive the same score as a boat not starting (DNS), without a hearing. This changes RRS A4, A5, and 63.1.

12. The Start

12.1 The starting line will be between the staff displaying an orange flag on the signal boat and the staff displaying an orange flag on the pin boat.

12.2 OCS boats may be hailed by sail number or bow number on VHF 71 (see SIs 1.4 and 23).

12.3 A boat not starting within 10 minutes after the starting signal will be scored DNS, without a hearing. This changes RRS A4, A5, and 63.1.

12.4 A Race Committee boat displaying code flag 'X', positioned near Mark 1, will attempt to notify OCS boats and will display their bow numbers.

12.5 A Race Committee boat displaying a 'U' or Black Flag, positioned near Mark 1, will attempt to notify boats that have been disqualified in accordance with RRS 30.3 or 30.4, respectively, and will display their bow numbers. Any boat notified that she has been disqualified shall leave the race course immediately. However, if there are two or more races scheduled for that day, boats having been disqualified in one race may stand by in an area outside the racecourse for the next race.

13. Change of Position of the Next Mark

To change the next leg of the course, the Race Committee will lay a new mark (or move the finishing line) and remove the original mark as soon as practicable. When in a subsequent change a new mark is replaced, it will be replaced by an original mark.

14. The Finish

The finishing line will be between the staff displaying a blue flag on a Race Committee boat and the nearby finishing mark.

15. Time Limit

15.1 The time limits will be as described in STCR 34.3.7, Format B.

15.2 Boats finishing more than 30 minutes after the first boat to finish will be scored 'Did Not Finish' (DNF), without a hearing. This changes RRS 35, A4, and A5.

16. Protests

16.1 Protest forms will be available at the protest desk at the Eastern Yacht Club Sailing Center, and shall be delivered there when completed.

16.2 Protest forms must be delivered within 60 minutes of the signal boat docking time. The protest time limit will be posted on the Official Notice Board. The same protest time limit applies to all protests by the Race Committee and Jury about incidents they observed in the racing area. This changes RRS 61.3 and RRS 62.2.

16.3 Notices will be posted on the Official Notice Board within 10 minutes of the protest time limit to inform competitors of hearings in which they are parties or named as witnesses. All parties and witnesses to a protest hearing shall meet at the protest desk at the scheduled hearing time.

16.4 A list of all boats that have been penalized for breaking RRS 42 will be posted as soon as practicable.

16.5 The race committee will post a list of penalties being assigned by the race committee prior to the end of the protest time limit. The deadline for requesting redress based on these scores will be either 30 minutes after the posting of the penalty notice or the protest time limit, whichever is later. This changes RRS 62.2.

16.6 On the last day of racing a request for redress based on a Jury decision shall be delivered no later than 30 minutes after the decision was posted. This changes RRS 62.2.

16.7 The penalty for breaking SI 18, 19, 20, 21, and 23 will be at the discretion of the Jury. For SI 20 the penalty may be applied to all boats associated with the team or a private support boat.

17. Scoring

A boat's series score will be the total of her race scores, with her worst score discarded when five (5) or more races are completed. Eight (8) races are scheduled, of which four (4) races shall be completed to constitute a series.

18. Liability and Safety

18.1 The safety of a boat and her entire management, including insurance, shall be the sole and inescapable responsibility of the owner and/or entrant.

18.2 Competitors leaving the race before the end of a race shall inform the Race Committee or a safety boat as soon as practicable.

19. Crew Changes

19.1 Any request for a change of crew must be submitted to the Jury in writing prior to 0800 hours on the day of the race for which the change is to be made. If the Jury grants permission, it will post its decision on the Official Notice Board.

19.2 A change of helmsman will not be permitted.

20. Team and Private Support Persons and Boats

20.1 As per RRS 1.1, a Support Persons and private spectator boats are expected to render assistance to a boat in danger when requested by the boat, or at the request of the Race Committee or Jury.

20.2 Support Persons shall stay 100 meters (300 Feet) outside the areas where boats are racing from the time of the Warning Signal until all boats have finished racing for the day.

20.3 A boat shall receive no outside assistance from Support Persons once she has left the dock for the day until the finish of the last race of the day, except in the case of emergency and/or towing supplied by the Organizing Authority or requested by the Race Committee.

20.4 The penalty for breaking 20.1, 20.2, or 20.3 will be at the discretion of the Jury, up to and including disqualification of all boats associated with the team or private Support Person(s).

21. Haul-Out Restrictions

Boats will be hauled-out according to the schedule posted by the Organizing Authority.

22. National Authority Prescriptions That Apply

Refer to Addendum #1, posted on the Official Notice Board, and the Sailing Instructions.

23. Radio Communication

23.1 A boat shall limit radio transmissions while racing.

23.2 The Race Committee may hail OCS boats on VHF Channel 71. (See SI 1.4 and SI12). Failure of the Race Committee to transmit, failure of a competitor to receive, mistaken transmissions, and the order of hail shall not be grounds for granting redress. This changes RRS 62.1(a).

24. Prizes

24.1 Perpetual trophies will be awarded in accordance with STCR 24.

24.2 Prizes will be awarded as follows:

First through fifth overall

Dailies first through third

First Master (50-59)

First Grandmaster (60-69)

First Exalted Grandmaster (70+)

First Vintage Division (Hulls under 8000)

25. Disclaimer of Liability

25.1 Competitors participate in this regatta entirely at their own risk. See RRS 4, Decision to Race.

25.2 Participants agree that no person or organization involved in the conduct of this Championship will be liable for any accident, injury, fatality, or damage or loss of boat or personal property arising out of a participant's preparation for and participation in any on-the-water or on-shore activities (whether social, recreational, launching, hauling, boat storage, or otherwise) associated with the Championship. Nothing in these Sailing Instructions or oral statements by the Organizing Authority, their officers, directors or agents, shall modify or otherwise impair the effect of the Waiver of Liability Form, the execution of which is a condition of entry.

Appendix A

Star Class Courses (STCR 34.3 and 34.4)

In case of small regattas the starting line may be set up at mark 3 and the finishing line at mark 1 or mark 3.

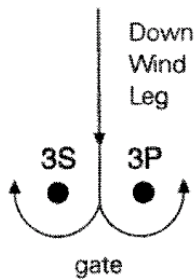

Courses 0, 1, 2, 3 and 4 are diagramed as described in STCR 34.3 and modified in the diagrams as allowed by STCR 34.4.

In Gold and Silver events, Course 0, 1, 3 or 4 shall be used. Course 2 may be used in Silver events if requested by the sponsoring fleet and approved by the Continental Committee.

In Blue and Green events Course 0, 1, 2, 3, and 4 shall be used.

No course may be shortened during Gold, Silver, Blue or Green Events.

In Red events and Qualifications the above courses are not mandatory and may be shortened.

Course "0"

Start
1
2
3
1
3 (or gate 3A - 3B)
Finish (upwind)

○ = optional offset mark

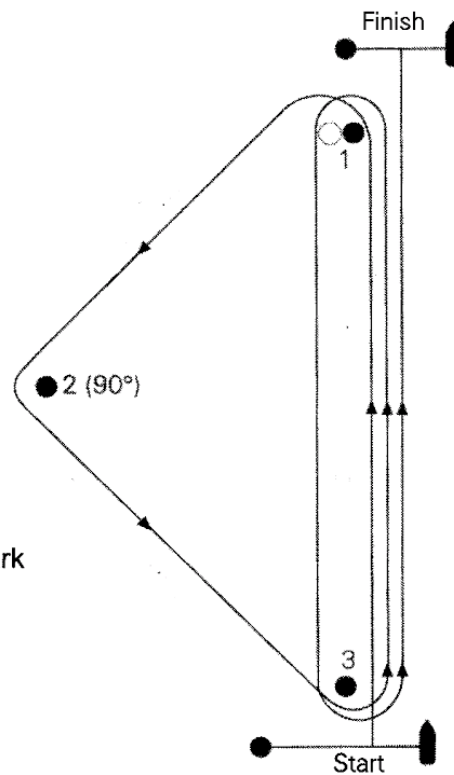

Course "1"

Start

1

2

3

1

(or 1 + offset mark)

Finish (downwind)

○ = optional offset mark

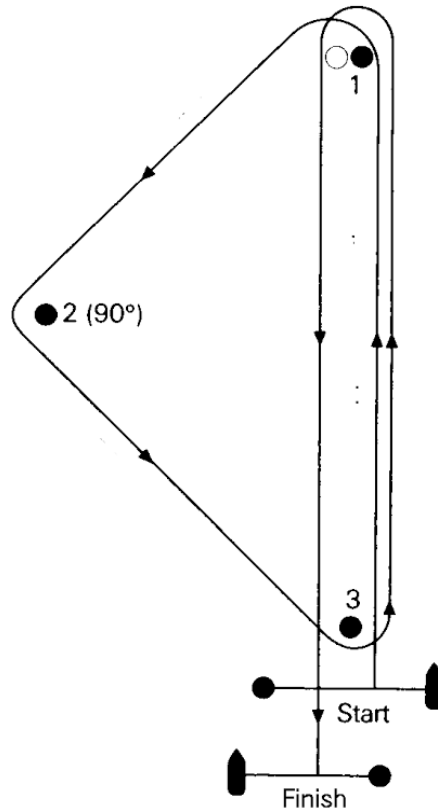

Course "2"

The same Course as Course "0"

Start

1

2

3

1

(or 1 + offset mark)

3 (or gate 3A - 3B)

1

2

3

Finish (upwind)

Course 2 may not be used at Gold events, and may only be used at Silver events with approval of the continental committee. (STCR 34.3.1)

Course "3"

Start

1

2

3 (or gate 3A-3B)

1

2

3 (or gate 3A-3B)

Finish (upwind)

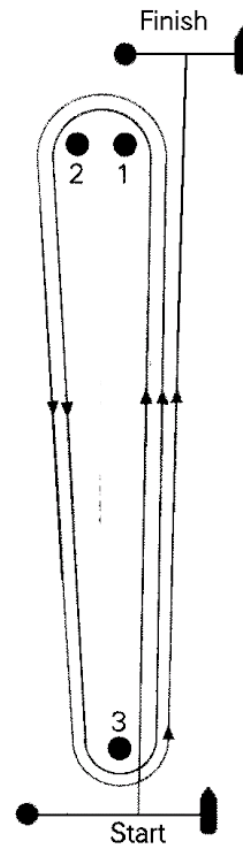

Course "4"

Start

1

2

3 (or gate 3A - 3B)

1

2

Finish (downwind)

